



# ALUMINUM OPEN CAR HAULER

## 3500 LB AXLE

PRICES EFFECTIVE: OCTOBER 1, 2021

### STANDARD EQUIPMENT

- 10 Year Limited Warranty on structure
- All aluminum construction with an extruded floor, rub rail and tie rail
- 2" X 3" extruded tubing crossmember on 16" centers for maximum torsional rigidity
- 2 – 3500 lb torsion axles
- 15" Aluminum wheels ST205/75R 15C tires
- GVWR rating 7770 lbs
- 2 5/16" coupler - 16" height, safety chains and safety breakaway system
- 2000 lb rated tongue jack
- 4 – 6,000 lb rated tie downs
- LED lighting
- 20" load height
- 7' 6" X 12" wide HD Ramps (2000 lb each) weighing 31 lb. each
- 2 – Hillsboro exclusive drop down rear stabilizer jacks
- 2 – removable aluminum fenders – 82 1/2" between fenders



## 2 RAMP

MODEL		AXLE	WEIGHT(LBS)	GVWR	REF#	LIST PRICE
75100	CH16RD	2-3.5K	1300	7770	AL370ER74	\$ 9,577
75101	CH18RD	2-3.5K	1350	7770	AL570ER15	\$ 9,760
75102	CH20RD	2-3.5K	1400	7770	AL670ER57	\$ 9,944

## 3 RAMP

MODEL		AXLE	WEIGHT(LBS)	GVWR	REF#	LIST PRICE
75100-003	CH16RD	2-3.5K	1380	7770	AL870ER90	\$ 10,247
75101-003	CH18RD	2-3.5K	1430	7770	AL080ER33	\$ 10,432
75102-003	CH20RD	2-3.5K	1480	7770	AL180ER74	\$ 10,616

\*\*ALL PRICES SUBJECT TO CHANGE, FINAL PRICING WILL BE CONFIRMED THROUGH ORDER VERIFICATION\*\*

\*\*PRICE EFFECTIVITY IS BASED ON ECD OF ORDER\*\*



# ALUMINUM OPEN CAR HAULER

## 5200 LB AXLE

PRICES EFFECTIVE: OCTOBER 1, 2021

### STANDARD EQUIPMENT

- 10 Year Limited Warranty on structure
- All aluminum construction with an extruded floor, rub rail and tie rail
- 2" X 3" extruded tubing crossmember on 16" centers for maximum torsional rigidity
- 2 – 5200 lb torsion axles
- 15" Aluminum wheels ST225/75R 15E tires
- GVWR rating 9990 lbs
- 2 5/16" coupler - 20" height, safety chains and safety breakaway system
- 2000 lb rated tongue jack
- 4 – 6,000 lb rated tie downs
- LED lighting
- 21.5" load height
- 6' X 12" wide HD Ramps (2500 lb each) weighing 25.4 lb. each
- 2 – Hillsboro exclusive drop down rear stabilizer jacks
- 2 – removable aluminum fenders – 82 1/2" between fenders



### 2 RAMP

MODEL		AXLE	WEIGHT(LBS)	GVWR	REF#	LIST PRICE
75111	CH18HD	5.2K	1680	9990	AL880ER62	\$ 11,509
75112	CH20HD	5.2K	1730	9990	AL190ER29	\$ 11,856
75113	CH22HD	5.2K	1780	9990	AL490ER42	\$ 12,262
75114	CH24HD	5.2K	1830	9990	AL790ER09	\$ 12,609

### 3 RAMP

MODEL		AXLE	WEIGHT(LBS)	GVWR	REF#	LIST PRICE
75112-003	CH20HD	5.2K	1810	9990	AL690ER46	\$ 12,527
75113-003	CH22HD	5.2K	1860	9990	AL990ER59	\$ 12,934
75114-003	CH24HD	5.2K	1910	9990	AL201ER25	\$ 13,279

# ACCESSORIES AND OPTIONS

		REF#	LIST PRICE
75246	Removable front air dam	AL700ES03	\$ 913
75250	Removable front bump rail	AL100ES51	\$ 196
75257	Winch plate	AL000ES66	\$ 86
233935	Spare aluminum wheel & tire (3500 Axle)	TI200LS22	\$ 288
233982	Spare aluminum wheel & tire (5200 Axle)	MI200TS47	\$ 321

**\*\*ALL PRICES SUBJECT TO CHANGE, FINAL PRICING WILL BE CONFIRMED THROUGH ORDER VERIFICATION\*\***  
**\*\*PRICE EFFECTIVITY IS BASED ON ECD OF ORDER\*\***

DIMENSIONS (INCHES)			
MODEL #	DIM X	DIM L	AXLE CENTER
CH16RD	192	244	78
CH18RD	216	268	90
CH20RD	240	292	102

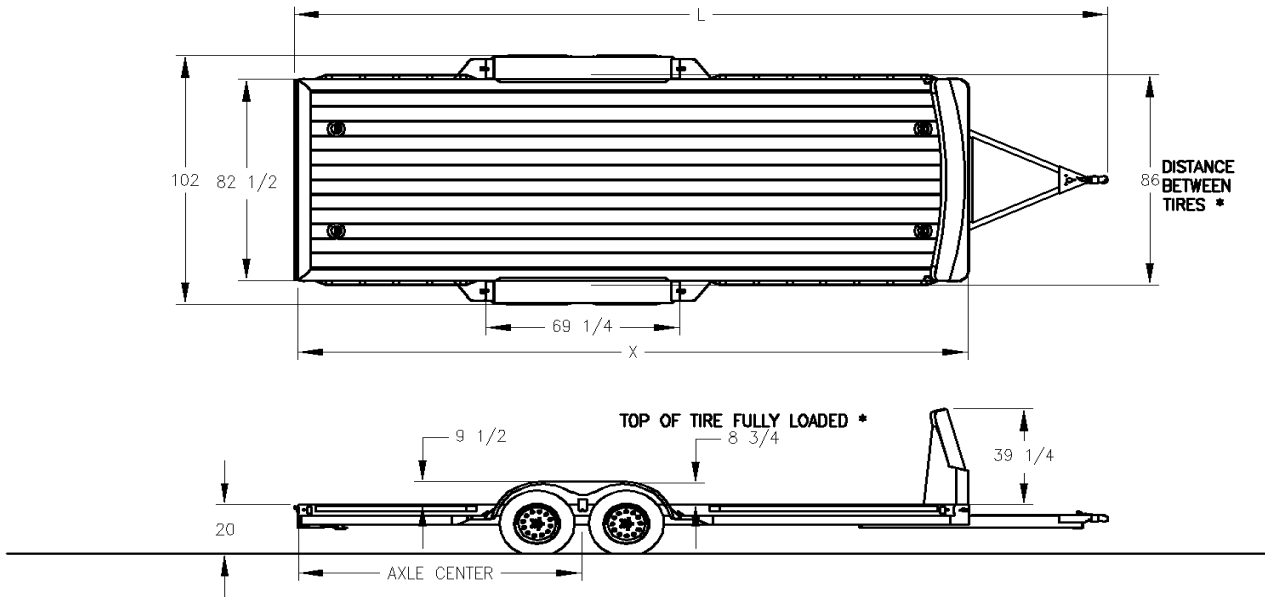

ALL DIMENSIONS ARE APPROXIMATE FOR STANDARD TRAILER IN UNLOADED CONDITION

SHOWN WITH OPTIONAL AERO GUARD \* WHEN FENDER REMOVED

TITLE						RD ALUMINUM CAR HAULER		Hillsboro Industries 220 Industrial Road Hillsboro, KS 67063		1-800-835-0209 hi@hillsboroindustries.com www.hillsboroindustries.com	
DWG NO.	REV	DATE	DRAWN BY	SCALE	PAGE						
?????	A	6-18	APD	1/50	1 OF 1						

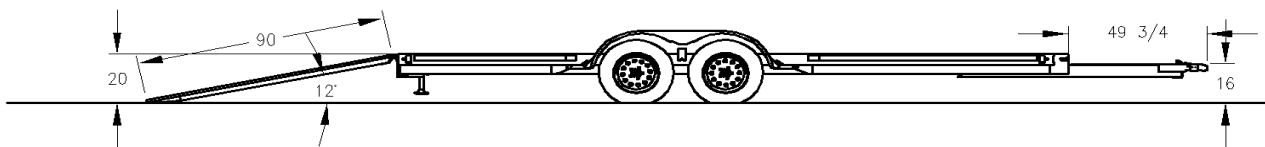

ALL DIMENSIONS ARE APPROXIMATE FOR STANDARD TRAILER IN UNLOADED CONDITION

TITLE						RD ALUMINUM CAR TRAILER		Hillsboro Industries 220 Industrial Road Hillsboro, KS 67063		1-800-835-0209 hi@hillsboroindustries.com www.hillsboroindustries.com	
DWG NO.	REV	DATE	DRAWN BY	SCALE	PAGE						
?????	A	6-18	APD	1/50	1 OF 1						

**\*\*ALL PRICES SUBJECT TO CHANGE, FINAL PRICING WILL BE CONFIRMED THROUGH ORDER VERIFICATION\*\***  
**\*\*PRICE EFFECTIVITY IS BASED ON ECD OF ORDER\*\***

DIMENSIONS (INCHES)			
MODEL #	DIM X	DIM L	AXLE CENTER
CH20HD	240	292	102
CH22HD	264	316	108
CH24HD	288	340	114

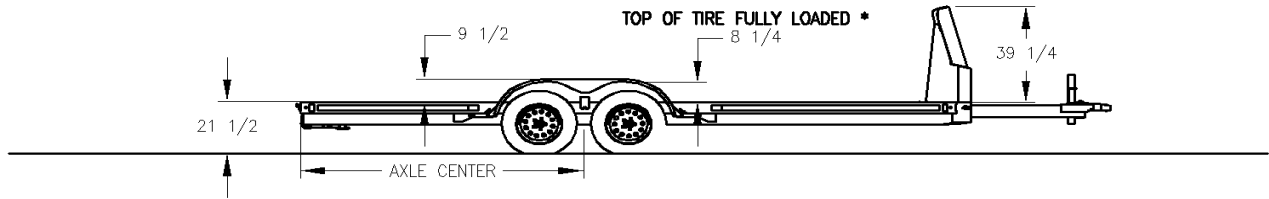
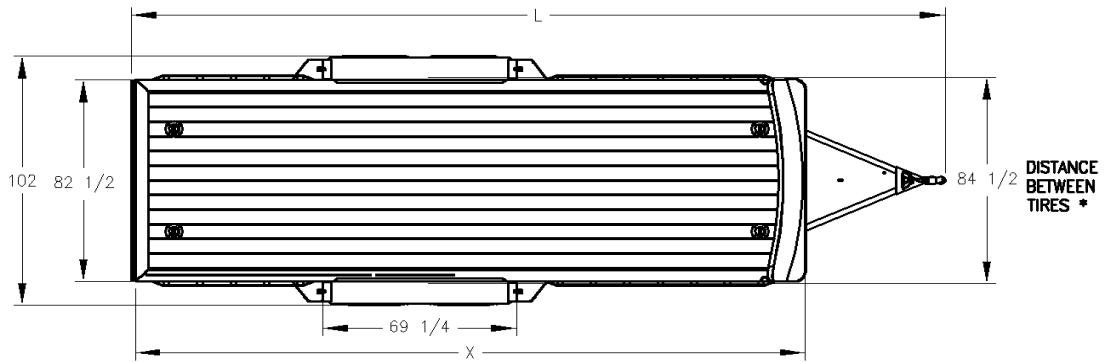

ALL DIMENSIONS ARE APPROXIMATE FOR STANDARD TRAILER IN UNLOADED CONDITION

SHOWN WITH OPTIONAL AERO GUARD  
\* WHEN FENDER REMOVED

TITLE						Hillsboro Industries		1-800-835-0209	
HD ALUMINUM CAR HAULER						220 Industrial Road		hi@hillsboroindustries.com	
DWG NO.	REV	DATE	DRAWN BY	SCALE	PAGE	Hillsboro, KS 67063		www.hillsboroindustries.com	
?????	A	12-18	APD	1/50	1 OF 1				

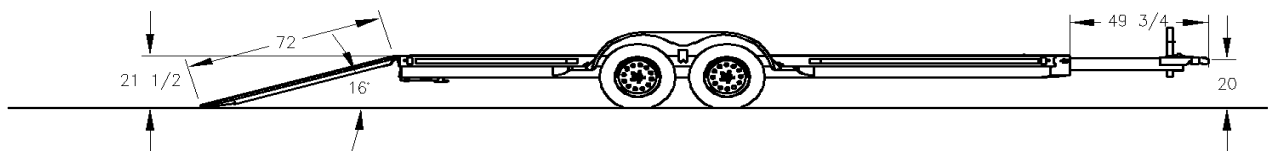

ALL DIMENSIONS ARE APPROXIMATE FOR STANDARD TRAILER IN UNLOADED CONDITION

TITLE						Hillsboro Industries		1-800-835-0209	
HD ALUMINUM CAR TRAILER						220 Industrial Road		hi@hillsboroindustries.com	
DWG NO.	REV	DATE	DRAWN BY	SCALE	PAGE	Hillsboro, KS 67063		www.hillsboroindustries.com	
?????	A	12-18	APD	1/50	1 OF 1				

**\*\*ALL PRICES SUBJECT TO CHANGE, FINAL PRICING WILL BE CONFIRMED THROUGH ORDER VERIFICATION\*\***  
**\*\*PRICE EFFECTIVITY IS BASED ON ECD OF ORDER\*\***